

## Vacuum degassing

Vacuum degassing is an important secondary steel making process. This process was originally used for hydrogen removal from the liquid steel but presently it is also being used for secondary refining and has become increasingly important process of secondary steel making. Pressure dependent reactions are the reason for the treatment of liquid steel in this process.

**Vacuum Degassing is mainly done for:**

- Hydrogen removal
- Nitrogen removal
- Production of Ultra low carbon steel (less than 30ppm)

**Types of Vacuum Degassers:**

**(i) Non Recirculating type**

- ❖ Ladle or Tank Degassers including VAD (Vacuum Arc Degassing) / VOD ( Vacuum Oxygen Decarburization)
- ❖ Stream Degassers

**(ii) Recirculating type**

- ❖ RH / RH-OB/ DH

In non-recirculating system, Argon is used as a stirring gas for the removal of H and N and to homogenize the bath.

In recirculating system Argon is used as a lifting gas to lower the density of liquid steel to be lifted up from the ladle to the vacuum vessel.

**Figure shows the schematic view of all of the various degassers.**

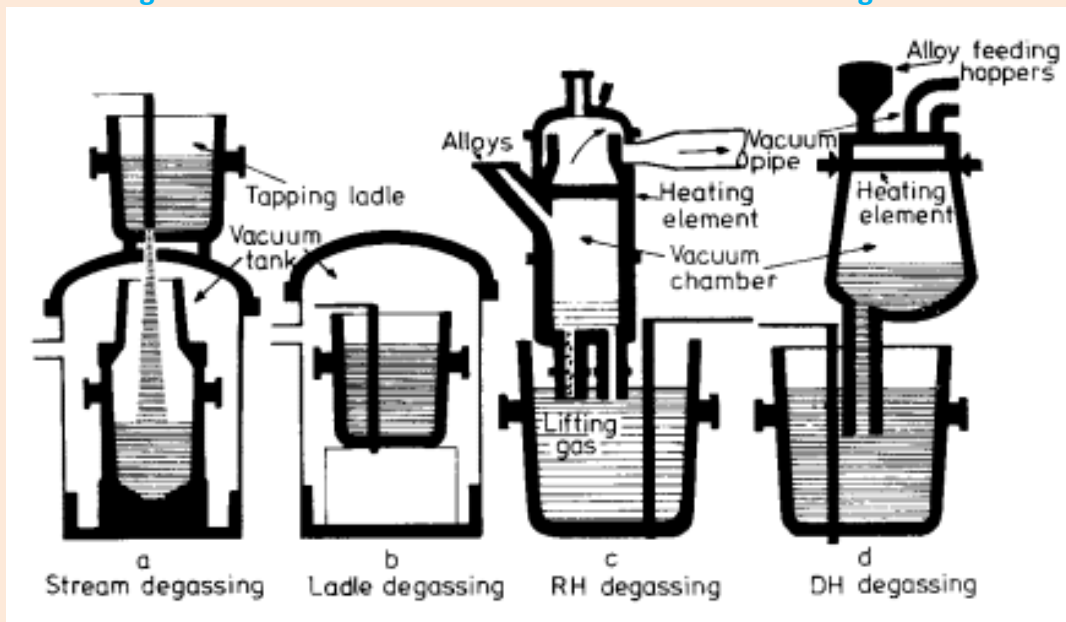

### Ladle degassing:

Ladle containing molten steel is placed in a chamber which is then evacuated. After a determined time ladle is removed from the chamber and is teemed for casting. Figure shows ladle degassing unit.

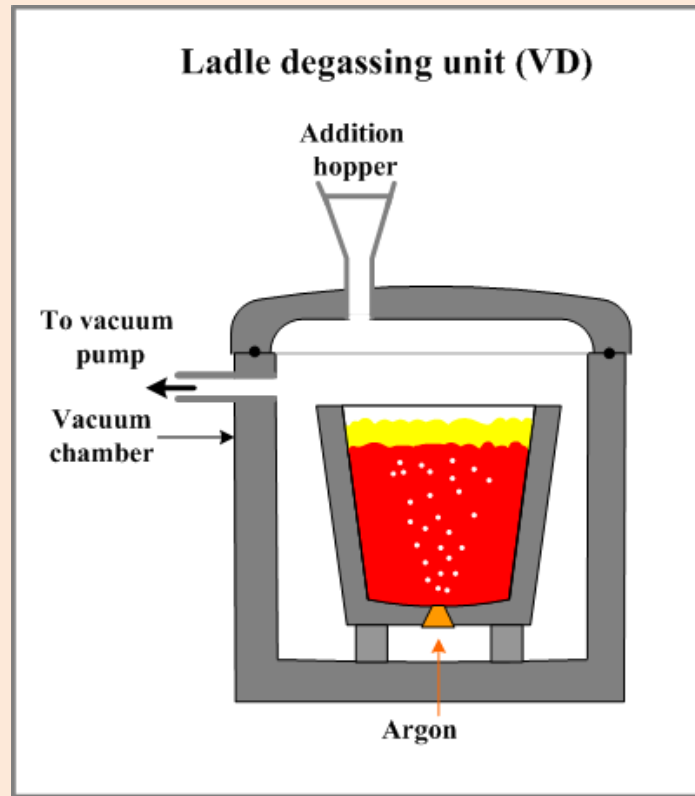

Ladle is provided with a porous plug at its bottom to purge Argon gas as shown in the figure. In a vacuum chamber the ladle is placed. The vacuum chamber is equipped with a hopper so as to make additions of elements as and when it is needed.

For effective degassing of fully killed steel, it is necessary to purge argon through the bottom of the ladle. Stirring the bath enhances rate of gas removal. Vigorous removal of gases causes metal splashing too. Therefore ladle is not filled completely and about 25% of its height is kept as freeboard to accommodate the splashed metal droplets. Pressure is maintained in between 1mmHg to 10mm Hg for effective degassing. During degassing additions are made for deoxidation and alloying.

In certain cases ladle is heated to compensate for the loss of heat during degassing. For the effectiveness of degassing, it is necessary that carry-over slag either from BOF or EAF should be as low as possible. Carry-over slag contains FeO and since oxygen content of steel is in equilibrium with FeO content of slag, oxygen content of steel increases.

Stirring gas is introduced either from top through the roof by a submerged refractory tube or through the porous plug fitted at the bottom of the ladle.

The final content of gas in steel depends on degree of vacuum and time of treatment. Hydrogen is generally reduced to below 2ppm from 4 to 6ppm, Nitrogen content of steel is also reduced. The pick-up of Nitrogen from the atmospheric air may occur during open pouring of steel, which must be controlled.

Ladles are generally lined with high alumina bricks at upper part of the ladle while the lower portion is lined with fireclay.

Vacuum arc degasser (VAD), the variant of VD has electrodes for the purpose of reheating the steel.

### Stream degassing:

In stream degassing technology, molten steel is teemed into another vessel which is under vacuum. Sudden exposure of molten stream in vacuum leads to very rapid degassing due to increased surface area created by breakup of stream into droplets. The major amount of degassing occurs during the fall of molten stream. Height of the pouring stream is an important design parameter.

Stream degassing technology has following variants in the practice

#### i. Ladle to mould degassing

Preheated mold with hot top is placed in vacuum chamber. Above the chamber a tundish is placed. Steel tapped in the ladle at superheat equivalent to 30°C is placed above the tundish. Steel is bottom poured in the tundish. One ingot could weigh around as high as 400tons and several heats from different furnaces are used for casting.

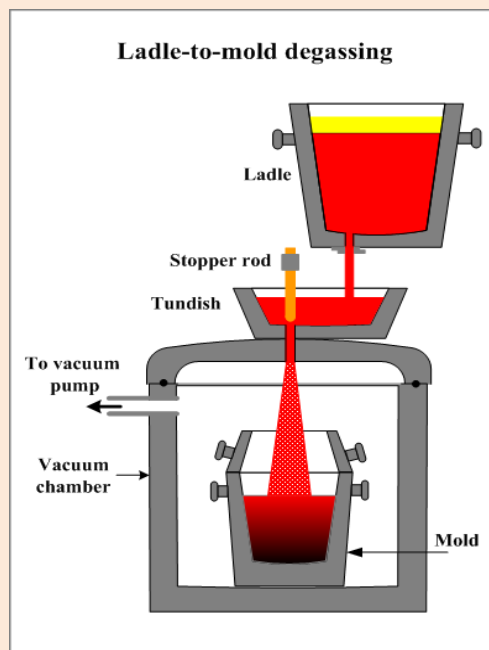

#### ii. Ladle to ladle degassing

In ladle to ladle degassing, a ladle with the stopper rod is placed in a vacuum chamber. Ladle containing molten steel from BOF or EAF is placed on top of the vacuum chamber and the gap is vacuum sealed. Alloy additions are made under vacuum. Stream is allowed to fall in the ladle where molten steel is degassed. Alloy additions are made under vacuum.

### Recirculation degassing

In the recirculation degassing technology, molten steel is allowed to circulate in the vacuum chamber continuously by special arrangement.

In recirculation type degassing two type of degassers are available.

- RH/ RH-OB degasser
- DH degasser

#### RH Degasser

In RH degassing technology (developed by Ruhrstahl Heraeus– Shutte at Hattingen, Germany), a cylindrical refractory lined shell with two legs (also called snorkel) is designed such that steel is raised in one leg and falls

back into the ladle after degassing through the second leg. Top side of the cylindrical shell is provided with exhaust, alloy additions, observation and control window.

**Figure: Arrangement of cylindrical vessel and ladle in RH degassing technology**

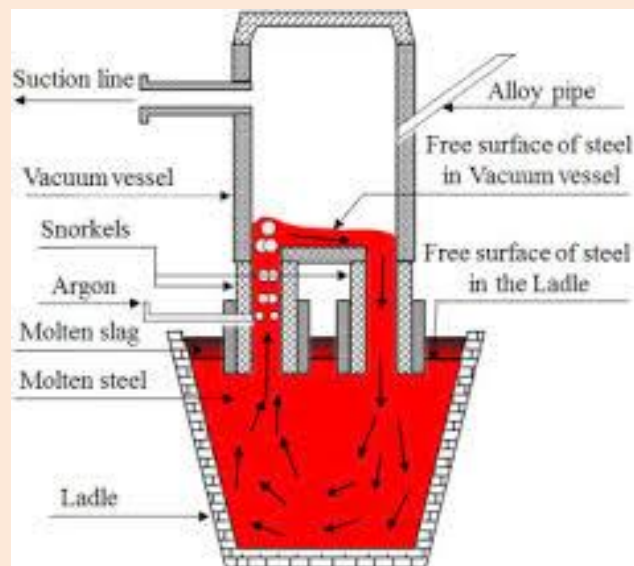

Shell is lined with fire bricks in the upper portion, and alumina bricks in the lower portion in order to sustain high temperature. The legs are lined with alumina refractory. A lifter gas argon is injected at the inlet snorkel in order to increase the molten steel velocity entering into inlet snorkel. Figure shows a schematic sketch of a RH degassing unit.

**The operation of RH degasser is as follows:**

1. Cylindrical chamber is heated to the desired temperature (between 900°C to 1500°C).
2. The chamber is lowered into molten steel up to a desired level so that snorkel dips into liquid steel.
3. The chamber is evacuated so that molten steel begins to rise in the chamber. Lifter gas is introduced. This gas expands and creates a buoyant force to increase the speed of molten steel rising into the inlet snorkel.
4. Molten steel in the chamber is degassed and flows back through the other snorkel into the ladle. This degassed steel is slightly cooler than steel in the ladle. Buoyancy force created by density difference (density of cooler liquid steel is > hot steel) stirs the bath
5. Rate of circulation of molten steel in cylindrical chamber controls the degassing. Circulation rate depends upon amount of lifter gas and the degree of vacuum.
6. Alloy additions can be made at the end of degassing depending on the superheat.
7. Process has several advantages like
  - Heat losses are relatively low.
  - Alloy additions can be adjusted more closely
  - Small vacuum pumping capacity is adequate since smaller volume is to be evacuated as compared with ladle to ladle or stream degassing.
  - Cleaner steel comparative to other processes.

RH-OB, the variant of RH, has provision of Oxygen blowing lance inside treatment vessel by the means of multi-function burner, which facilitates to get ultra-low level of C in the liquid steel.

**DH Gassing:**

In DH (Dortmund Hoerder) degassing, a small amount 10-15% of the total mass of steel is degassed at a time. The process is repeated until required level of degassing is achieved. The arrangement of a vessel and the ladle is somewhat similar to RH except the following:

- In DH unit, the cylindrical vessel has a single snorkel.

- Cylindrical vessel has heating facility

Figure: Arrangement of DH degassing technology

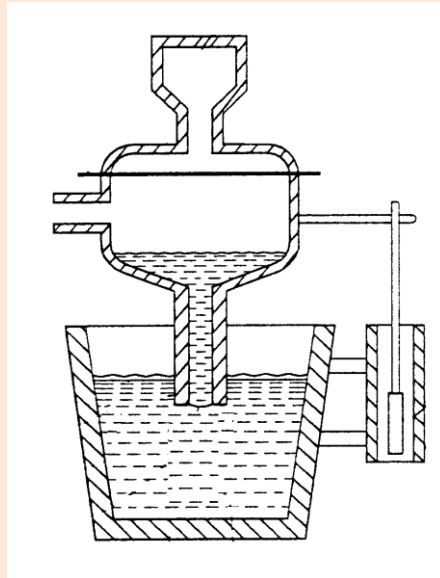

The DH chamber is equipped with heating facility, alloying addition arrangement and exhaust systems. Bottom of the cylindrical vessel is provided with a snorkel which can be dipped into molten steel. The upper portion of the DH vessel is lined with the fireclay and the lower portion with the alumina bricks, snorkel is lined with high quality alumina brick. The length of the snorkel is sufficiently large to realize the effect of atmospheric pressure on rise of steel in the snorkel. The following steps may be noted for operation:

- DH vessel is preheated and lowered in the ladle so that snorkel tip dips below the molten steel surface
- The evacuated chamber is moved up and down so that steel enters the chamber
- The chamber is moved for 50-60 times with a cycle time of 20 seconds.
- Adequate degassing is possible in 20 -30 cycles.
- A layer of slag is kept in the ladle to minimize heat losses.
- The DH degassing unit can operate with lower superheats compared with RH since DH unit has heating facility

**Comparison of various Degassing process:**

Parameter	RH-OB	RH	VD	Ladle Degassing
Carbon content –final product, ppm	< 20	< 20	30-40	30-40
Decarburization rate	Very high	Sufficient for LC steels	20-30% less than with RH-OB	
Decarburization time, min	< 13	< 15	15-20	20
Steel cleanliness	All systems improve steel cleanliness / VD and ladle degassing need soft stirring period			
Desulphurization	Powder injection by lance – seldom	No	Very efficient	-
Chemical heating	Yes	No	No	No
Relative capital costs	1	0.8-0.9	0.4-0.5	0.3-0.4
Operating Cost	Decreasing			

**Submitted by**  
**Shri. S.K.Gupta**  
**Asst. Mgr (Steel)**